

	<p style="text-align: center;"><b>INSTITUCIÓN EDUCATIVA ALFONSO LÓPEZ PUMAREJO</b> Virtud – orientación y ciencia</p>	 Alcaldía de Medellín Secretaría de Educación
Fecha: 9 de Noviembre de 2016	Actividades complementarias de superación - ACES	Grado: 6°
Área: Humanidades: Idioma Extranjero, Inglés.	Docente(s): César Augusto Murillo Hoyos. Emilse Pájaro Beleño.	
<p>Indicadores de desempeño: Describa lo que debería poder hacer o argumentar un estudiante para evidenciar que alcanzó los aprendizajes esperados (estándares y DBA). Tenga en cuenta que es necesario precisar las evidencias de comprensión o de desarrollo de habilidades por parte de los estudiantes, en coherencia con los objetivos propuestos para el área.</p> <p><b>PRIMER PERÍODO</b></p> <ul style="list-style-type: none"> <li>• Reconocimiento del vocabulario referido al salón de clase.</li> <li>• Conocimiento de palabras para saludar y despedirse.</li> <li>• Empleo de las preguntas de información básicas que le permiten comunicarse con los demás.</li> <li>• Interés por conocer e interrelacionarse con sus compañeros mediante el uso del idioma.</li> </ul> <p><b>SEGUNDO PERÍODO</b></p> <ul style="list-style-type: none"> <li>• Descripción de personas, lugares y objetos.</li> <li>• Asimilación de estructuras básicas y vocabulario.</li> <li>• Elaboración de textos cortos acerca de descripciones de personas, lugares y cosas en forma oral y escrita.</li> <li>• Reconocimiento de las normas básicas de cortesía para dirigirse a los miembros de la comunidad educativa con el fin de aprender como convivir.</li> </ul> <p><b>TERCER PERÍODO</b></p> <ul style="list-style-type: none"> <li>• Descripción de personas, lugares y objetos.</li> <li>• Asimilación de estructuras básicas y vocabulario.</li> <li>• Enlace de oraciones con el verbo to be.</li> <li>• Interés en conocer e interrelacionarse con sus compañeros a través del uso del lenguaje.</li> </ul> <p><b>CUARTO PERÍODO</b></p> <ul style="list-style-type: none"> <li>• Asimilación de estructuras básicas y vocabulario.</li> <li>• Manejo de preguntas de información.</li> <li>• Expresión de la información personal de sí mismos y de otros compañeros ante el grupo.</li> <li>• Expresión de hechos con facilidad que hacen parte de su cotidianidad.</li> </ul>		
<p>Instrucciones: Tenga en cuenta para la realización del presente taller los siguientes aspectos:</p> <ol style="list-style-type: none"> <li>a) Señor padre de familia o acudiente: en el día de hoy se le está notificando que su hijo (a)/ acudido (a) debe participar en el proceso de ACES (Actividades Complementarias Especiales de Superación) en el área de Humanidades: Idioma Extranjero, Inglés.</li> <li>b) Este proceso se realizará en tres etapas:             <ul style="list-style-type: none"> <li>- La primera es la notificación que se le está haciendo en el día de hoy.</li> <li>- La segunda será una asesoría en la que se precisarán ideas, conceptos y procedimientos relacionados con el proceso de aprendizaje del estudiante. Esta asesoría se realizará el día Lunes 21 de noviembre a las 6:45 am y para dicha sesión el estudiante deberá entregar el</li> </ul> </li> </ol>		

presente taller resuelto.

- La tercera será la presentación de la sustentación que puede ser en forma oral o escrita, de acuerdo a como lo estipule el respectivo docente. Esta sustentación se realizará el día Miércoles 23 de noviembre a las 6:45 am.
- c) Al finalizar el proceso se asignará al estudiante una nota máxima aprobatoria de 3.0. Quien no la obtenga, no habrá desarrollado la competencia para superar el área.

1. Exploración: Reconocimiento de los desempeños bajos de los estudiantes.

2. Asesoría:

Explicación y repaso de cada uno de los siguientes temas:

- Greetings and Farewells
- Introductions
- Personal Information Questions
- Me and my family
- My things
- My school
- My perfect life
- Descriptions.
- Likes and Dislikes.
- Daily Routines

3. Actividad:

Los estudiantes deberán desarrollar el taller que se presenta posteriormente y que da cuenta de los núcleos temáticos vistos a través del año escolar correspondientes a las competencias específicas que los estudiantes deben desarrollar en el proceso de aprendizaje de la lengua extranjera. Igualmente el docente de su grupo le indicará los componentes del taller que deberá tener en cuenta para prepararse para la sustentación.

Plazo para entregar y resolver: Lunes 21 de Noviembre a las 6:45 am.

**Nota:** No se admitirá la entrega de fotocopias de otros trabajos. Si el estudiante incurre en esta falta (plagio), se le dará una valoración de 1.0 en el 30% del Hacer y asumirá las sanciones que se le presenten a nivel disciplinario.

4. Valoración: Verificación de los objetivos de aprendizaje propuesto. Contempla un:

- Hacer 30% (realización y presentación del taller según los criterios determinados por el docente)
- Saber 60% (Sustentación – El estudiante debe demostrar los conocimientos adquiridos)
- Ser 10% (actitud del estudiante en el proceso. Puntualidad, asistencia, compromiso entre otros)

5. Observaciones generales:

- Es importante leer muy bien el presente instructivo e interiorizar la distribución de los porcentajes que se asignarán a cada uno de los componentes del desempeño del estudiante (Saber, Hacer y Ser) para que de esta forma tenga claridad en el manejo de la evaluación.
- Es importante asistir muy puntualmente a los momentos que se estipulan para el proceso de ACES (notificación, asesoría y sustentación).
- Tenga en cuenta las fechas estipuladas para cada una de las etapas de entrega de talleres o realización de actividades. El estudiante Debe ser puntual ya que si no se presenta en los días y horas establecidas (a menos que demuestre calamidad doméstica o excusa médica de peso validada por coordinación), perderá la posibilidad de participar en la etapa respectiva del proceso.

- Tenga presente que tanto el trabajo, como la sustentación y su actitud en ellos, generan un porcentaje de la nota y completar todo el proceso le puede ayudar a obtener un resultado positivo.
- Presentar el proceso no es garantía de obtener un desempeño básico, solo la realización de un trabajo bien presentado y una buena sustentación, lo hace.

## WORKSHOP

### COMPONENTE PRIMER PERÍODO

A. Match questions in column A with answers in column B. Look at the example.

#### COLUMN A

1. What's your name?
2. How old are you?
3. Where are you from?
4. What is your nationality?
5. What language do you speak?
6. What is your cell phone number?
7. What is your e-mail address?





#### COLUMN B

- a) It is 3045568422.
- b) I am Colombian.
- c) It is thebadboy342@gmail.com
- d) Spanish.
- e) My name is Rodrigo.
- f) I am from Colombia.
- g) 39 years old.

A. Complete the nationalities with the endings "-an", "-ish", "-ch", "-ese".

- |                |                   |
|----------------|-------------------|
| 1. Americ_____ | 5. Span_____      |
| 2. Brit_____   | 6. Dut_____       |
| 3. Fren_____   | 7. Portugu_____   |
| 4. Japan_____  | 8. Argentini_____ |

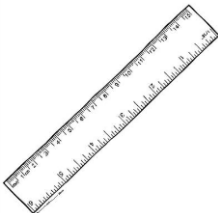
B. Write the names in English for the following classroom objects.

 1. _____ _____	 2. _____ _____	 3. _____ _____	 4. _____ _____	 5. _____ _____
---	---	---	--	---

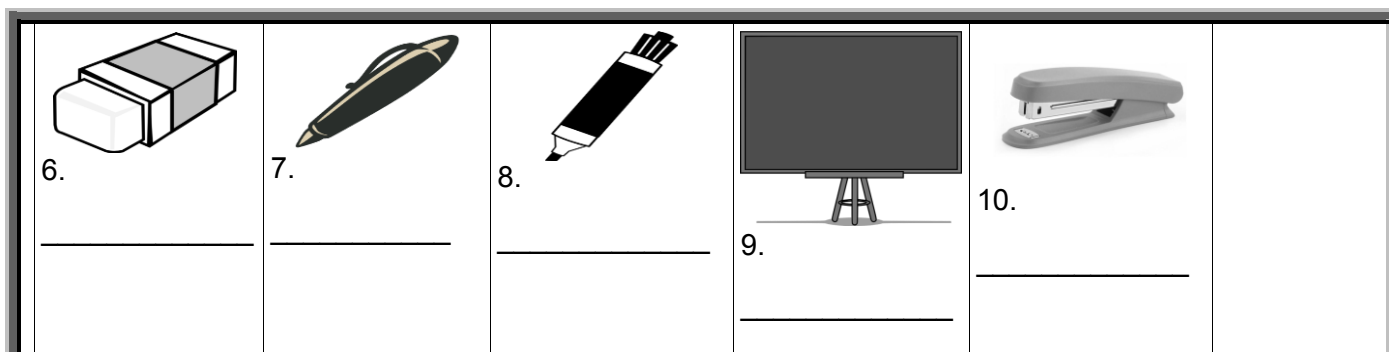

Pictures taken from:

[http://www.clipartpanda.com/clipart\\_images/vocabulary-units-complete-18909413](http://www.clipartpanda.com/clipart_images/vocabulary-units-complete-18909413)

<http://www.newtechmachinery.com/coil-calculators/>

<https://www.pinterest.com/pin/84935142948794419/>

<https://mlpforums.com/topic/110391-will-twilight-ever-become-a-ruler/>

<https://www.whsmith.co.uk/products/whsmith-festival-pink-floral-union-jack-filled-pencil-case/35709442>

<http://www.clipartpanda.com/categories/eraser-clipart>

<http://www.iconarchive.com/tag/pen>

<http://www.clipartpanda.com/categories/markers-clipart>

<http://www.clipartkid.com/board-cliparts/>

<https://www.aliexpress.com/popular/manual-stapler.html>

**C.** Complete the conversation with the expressions in the box.

Nice to meet you too.	Thank you	This is	Hello Norma	Goodbye
I'm good	See you	What is your full name	What is your nationality	How old are you

Norma: Hi Carlos.

Carlos: \_\_\_\_\_ . How's it going?

Norma: fine \_\_\_\_\_ and you?

Carlos: \_\_\_\_\_ , thanks.

Norma: \_\_\_\_\_ my best friend, Rita.

Carlos: Nice to meet you, Rita.

Rita: \_\_\_\_\_

Carlos: \_\_\_\_\_ ?

Rita: It's Rita Alonso Sánchez. \_\_\_\_\_?

Carlos: I am 30 years old. \_\_\_\_\_?

Rita: I am Mexican.

Norma: Ok, Carlos. \_\_\_\_\_ later.

Carlos: Ok \_\_\_\_\_.

**D.** Fill in the blanks by writing the numbers according to the result of the mathe operations. Take a look at the example to know how to do it. Example: five + three = 8

1. \_\_\_\_\_ + \_\_\_\_\_ = 9

2. \_\_\_\_\_ + \_\_\_\_\_ = 10

3. \_\_\_\_\_ - \_\_\_\_\_ = 3

4. \_\_\_\_\_ - \_\_\_\_\_ = 5

5. \_\_\_\_\_ x \_\_\_\_\_ = 12

6. \_\_\_\_\_ x \_\_\_\_\_ = 24

7. \_\_\_\_\_ ÷ \_\_\_\_\_ = 2

8. one ÷ \_\_\_\_\_ = 1

## COMPONENTE SEGUNDO PERÍODO

### SECTION A (PICTURE READING)

Look at the following picture and choose the option that best fits the description given. Mire la siguiente imagen y escoja la opción que concuerde mejor con la descripción dada.



1. Homer Simpson's body is \_\_\_\_\_:

a) Fat

- b) Slim  
c) Skinny  
d) Lean
2. Homer Simpson \_\_\_\_\_ bald.  
a) is  
b) am  
c) are  
d) has
3. Homer Simpson has a \_\_\_\_\_ nose.  
a) Big  
b) Small  
c) Hooked  
d) Hawkish
4. Homer Simpson has \_\_\_\_\_ eyes.  
a) Small  
b) Big  
c) Almond-shaped  
d) Long

### SECTION B (GRAPH READING)

Look at the chart. Choose the right option according to the statements. Mire el cuadro. Elija la opción correcta de acuerdo a los enunciados.

NAME	AGE	HEIGHT	WEIGHT
PAULA	20	1.90	80 kg
ANDRÉS	35	1.50	50 kg
CÉSAR	80	1.65	100 g

5. Paula is...  
a) Short, heavy, and old.  
b) Short, average weight and young.  
c) Tall, average weight, and old.  
d) Tall, thin, and young.
6. Andrés is...  
a) Middle aged, heavy, and tall.  
b) Young, thin, and average height.  
c) Old, heavy, and short.  
d) Middle aged, average weight, and short.
7. César is...  
a) Average height, old, and heavy.  
b) Short, young, and thin.  
c) Tall, old, and heavy.  
d) Tall, young, and average weight.

### SECTION C (SYNTAX)

8. Unscramble the following negative sentences. Ordene las siguientes oraciones negativas.

a) Manolo Cardona / Singer / not / is /a

---

b) Not/ is/ Paola Turbay/ American / actress/not

---

c) Pibe and Asprilla /are / doctors/ not /

---

d) Not / Shakira/ Australian/ is/ an/ singer

---

e) Not/ am / a/ stupid/ person / I

---

9. Unscramble the following sentences. Ordene las siguientes oraciones.

a) Are /we /at/ ALPUMA/ studying/ English/school

---

b) You/ writing / are / in/ class

---

c) Not/ am/ I / living/ in /Santa Marta

---

d) My Father / not/ working / is / today

---

e) Not/ My/ mother / is /eating/in/ a /restaurant

---

10. Write the words in the correct order to make questions with verb be. Escriba las palabras en el orden correcto para hacer preguntas con el verbo "Be".

**Example:** you /hot?/ Are  
Are you hot?

a) book? /your/ Is/ this

---

b) Peters /Mr. /Is/ the /Unites/ from /States?

\_\_\_\_\_

c) they/ married? /Are

\_\_\_\_\_

d) Jenkins?/ Are/ Mrs. /you / and/ Mr./

\_\_\_\_\_

e) Alice /and /are/ you/Jane?

\_\_\_\_\_

<http://www.eclecticenglish.com/grammar/PresentSimpleToBe1A.html>

#### SECTION D (GRAMMAR)

11. Complete with “am”, “is” or “are”. Complete con “am”, “is” o “are”. Example: I am from France.

a) Paola Rey \_\_\_\_\_ an actress. She \_\_\_\_\_ pretty and thin. She \_\_\_\_\_ Colombian.

b) Jacky Chan \_\_\_\_\_ a film star. He \_\_\_\_\_ Chinese. He \_\_\_\_\_ young.

c) Natalia Paris and Claudia Shiffer \_\_\_\_\_ models. They \_\_\_\_\_ slim.

d) Ronaldinho and Messi \_\_\_\_\_ football players. They \_\_\_\_\_ medium height and young.

e) It \_\_\_\_\_ cold today.

f) I \_\_\_\_\_ at home now.

g) They \_\_\_\_\_ Korean.

h) My name \_\_\_\_\_ Nikita.

i) We \_\_\_\_\_ from Ukraine.

j) I \_\_\_\_\_ OK, thanks.

k) We \_\_\_\_\_ from Venezuela.

l) They \_\_\_\_\_ married.

m) She \_\_\_\_\_ an English teacher.

n) You \_\_\_\_\_ an engineer.



12. Complete the gaps with “am not”, “are not” and “is not”. Complete los espacios con “am not”, “are not” and “is not”.

Example: She is not from France.

- This book \_\_\_\_\_ mine.
- I \_\_\_\_\_ at home now.
- They \_\_\_\_\_ Korean.
- Jane and Peter \_\_\_\_\_ married.

13. Answer in English. Responda en inglés:

- Is My mom pretty ? \_\_\_\_\_
- Is my Dad tall? \_\_\_\_\_
- Are my brothers students? \_\_\_\_\_
- Are you happy ? \_\_\_\_\_

### COMPONENTE TERCER PERÍODO

1. Complete the gaps with “am not”, “are not” or “is not”. Complete los espacios con “am not”, “are not” o “is not”.

Example: She is not from France.

- My brother \_\_\_\_\_ here.
- We \_\_\_\_\_ in England.
- It \_\_\_\_\_ Monday today.
- I \_\_\_\_\_ a hairdresser.
- My name \_\_\_\_\_ Alexander.
- You \_\_\_\_\_ from this school.

2. Look at the pictures and write short phrases on what you like or dislike based on the pictures. Mira los dibujos y escribe frases cortas acerca de lo que les gusta y lo que no les gusta basado en las imágenes.



a) \_\_\_\_\_



b) \_\_\_\_\_



c) \_\_\_\_\_

3. Order the following sentences. Ordene las siguientes oraciones.

a) classical my likes mother to music listening

b) his dad car Ana's washing hates

c) travelling friend by loves my plane father's

d) emails writing I long hate

e) watching dislikes films horror she TV on

f) likes to She talking friends

g) computer don't playing I games like

h) listening He like to doesn't music

i) watching like TV I

j) She writing like e-mails doesn't

4. Write "love" or "loves" (😊😊), "like" or "likes" (😊), "don't like" or "doesn't like" (😞), or "hate" or "hates" (😞😞). Escriba "love" o "loves" (😊😊), "like" o "likes" (😊), "don't like" o "doesn't like" (😞), o "hate" o "hates" (😞😞).

a) I \_\_\_\_\_ eating pizza on Saturdays (😊😊).

b) My sister \_\_\_\_\_ tidying her room (😞😞).

c) She \_\_\_\_\_ making dinner on Mondays (😞).

d) Arthur \_\_\_\_\_ playing rugby with his friends (😊😊).

e) My aunt \_\_\_\_\_ driving at night (😞😞).

f) Your brothers \_\_\_\_\_ sleeping in the tent (😊).

g) Those children \_\_\_\_\_ listening to the radio (😊😊).

- h) These men \_\_\_\_\_ working on Sundays (😞).  
 i) My niece \_\_\_\_\_ reading adventure books (😞).  
 j) Your father's friends \_\_\_\_\_ driving their cars when it is raining.

<http://www.englishexercises.org/makeagame/viewgame.asp?id=3674>

5. Complete with "don't" or "doesn't". Complete con "don't" o "doesn't".

- a) You \_\_\_\_\_ live in Santa Marta.  
 b) They \_\_\_\_\_ drink beer.  
 c) The boy \_\_\_\_\_ cry in the park.  
 d) My sister \_\_\_\_\_ do homework.  
 e) The children \_\_\_\_\_ dance very well.  
 f) Juanes \_\_\_\_\_ sing in Cienaga.  
 g) You \_\_\_\_\_ very well.  
 h) We \_\_\_\_\_ beer .  
 i) Richard \_\_\_\_\_ literature books.  
 j) My Aunt \_\_\_\_\_ chicken.  
 k) The children \_\_\_\_\_ tv at night

6. Answer in English. Responda en Inglés.

- a) Do you study in Medellín? \_\_\_\_\_.  
 b) Does Cesar teach very well? \_\_\_\_\_.  
 c) Do we learn English every day? \_\_\_\_\_.  
 d) Does Carlos Vives sing vallenato music? \_\_\_\_\_.  
 e) Do Paola Rey and Danna Garcia work on television? \_\_\_\_\_.  
 f) Does my father work all week? \_\_\_\_\_.  
 g) Do you like English ? \_\_\_\_\_  
 h) Do we have vacation very soon ? \_\_\_\_\_  
 i) Does Cabas sing vallenato music? \_\_\_\_\_  
 j) Do Shakira and Maia sing pop music ? \_\_\_\_\_

## COMPONENTE CUARTO PERÍODO

### SECTION A (MATCHING EXERCISE)

1. Match the words to make phrases.
- |           |            |
|-----------|------------|
| a. Wash   | the floor  |
| b. Vacuum | the celery |
| c. Cut    | water      |
| d. Boil   | the dishes |

### SECTION B (PICTURE-DEFINITION ASSOCIATION)

Look at the pictures and descriptions and choose the activity corresponding to each statement.



2. He plays soccer.

- a) 1
- b) 2
- c) 3
- d) 4

3. He watches TV.

- a) 1
- b) 2
- c) 3
- d) 4

4. He listens to music.

- a) 1
- b) 2
- c) 3
- d) 4

5. She takes photographs.

- a) 1
- b) 2
- c) 3
- d) 5

6. He plays video games.

- a) 1
- b) 2
- c) 3
- d) 4

7. They put a puzzle together.

- a) 1
- b) 3
- c) 5
- d) 6

Answer the questions by taking into account the activities performed in the pictures.

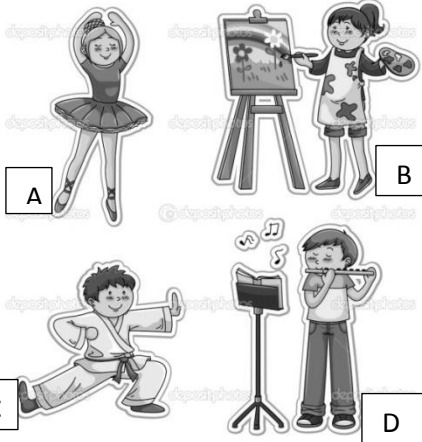

8. Is the girl in picture A dancing salsa?
- a) Yes, she is
  - b) No, she isn't
  - c) Yes, she does
  - d) No, she doesn't
9. Is the boy in picture C playing tennis?
- a) Yes, he is
  - b) Yes, he does
  - c) No, he isn't
  - d) No, he doesn't
10. Can the girl in picture B paint?
- a) Yes, she can
  - b) No, she can't
  - c) Yes, she does
  - d) No, she doesn't

### SECTION C (PICTURE READING)

Choose the right option for the questions and the statement by taking into account the pictures in the chart.

	1		2
--	---	--	---

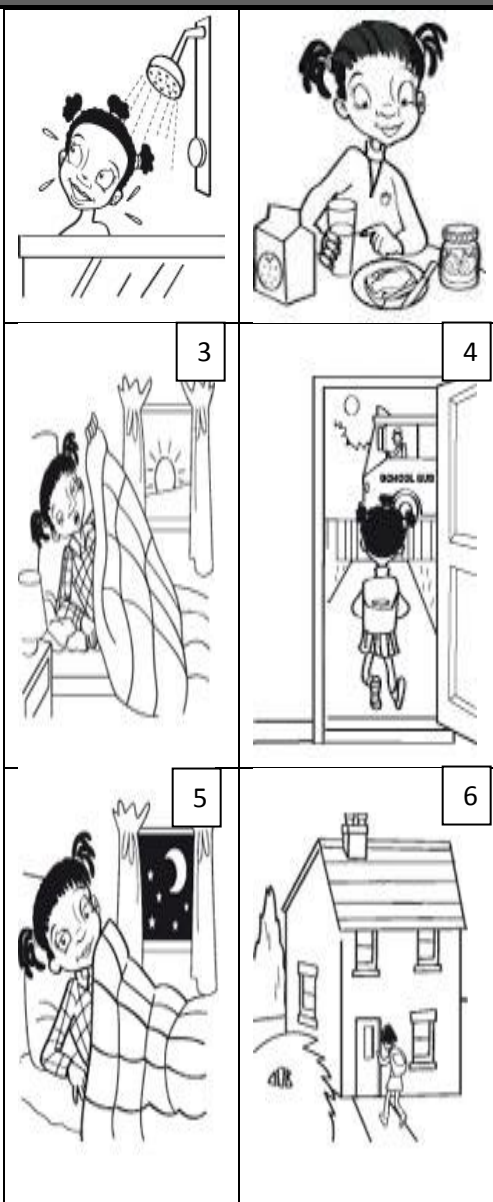

Pictures taken from:

<https://elt.oup.com/student/coolkids/coolkids4/picturebank/unit4?cc=us&sellLanguage=en>

11. What is the girl doing in picture 4?

- a) She is going to school.
- b) She is going home.
- c) She is eating breakfast.
- d) She is sleeping.

12. What is the girl doing in picture 5?

- a) She is going to sleep.
- b) She is getting up.
- c) She is eating breakfast.

- d) She is taking a shower.
13. What is the girl doing in picture 1?  
a) She is getting up.  
b) She is eating breakfast.  
c) She is taking a shower.  
d) She is sweeping the floor.
14. What is the girl doing in picture 3?  
a) She is sleeping.  
b) She is getting up.  
c) She is eating lunch.  
d) She is getting dressed.
15. What is the girl doing in picture 2?  
a) She is eating breakfast.  
b) She is watching TV.  
c) She is combing her hair.  
d) She is drying her hair.
16. What is the girl doing in picture 6?  
a) She is going to school.  
b) She is going home.  
c) She is driving a car.  
d) She is leaving the house.
17. A logical order for this sequence is:  
a) 123456  
b) 246513  
c) 654321  
d) 312465

#### **SECTION D (READING COMPREHENSION)**

Read the following text.

Hi, I will tell you about my daily routine. I get up at 6.00. I brush my teeth, have a shower, and eat breakfast. I go to school at 6.50, and I start classes at 7.20. Then, I have lunch at 12.30, and finish school at 15.40. I go to bed at 21.30. That's my day!

Taken from <http://www.abc.com.py/articulos/daily-routines-and-descriptions-1049235.html>

Now choose the right option when answering the following questions.

18. What time does this person go to bed?  
a) This person goes to bed at 8:30 p.m.  
b) This person goes to bed at 9:30 p.m.  
c) This person goes to bed at 10:30 p.m.  
d) This person goes to bed at 11:30 p.m.
19. What does this person do immediately after brushing his/her teeth?  
a) This person takes a shower immediately after brushing his/her teeth.  
b) This person goes to school immediately after brushing his/her teeth.  
c) This person finishes school immediately after brushing his/her teeth.  
d) This person has breakfast immediately after brushing his/her teeth.
20. What does this person do before eating breakfast?  
a) This person goes to bed before eating breakfast.  
b) This person takes a shower before eating breakfast.  
c) This person goes to school before eating breakfast.

d) This person has lunch before eating breakfast.

Read the following interview and choose the best option for every single statement. Lea la siguiente entrevista y elija la mejor opción para cada uno de los enunciados.

Interviewer: today is the second school day of a normal week at I.E. Alfonso López Pumarejo. It's 6:40 in the morning and I am with student Pedrito Pérez from 6<sup>th</sup> grade. Pedrito, what are your daily routines in the morning?

Pedrito Pérez: Good morning mister interviewer. Normally, I wake up at 6:00 am. I live in Manzanares. I get up and take a shower. My mother makes breakfast. After my shower, I get dressed and eat breakfast. Then, I brush my teeth and leave for school at 6:20 a.m. I am in school from 6:45 am to 12:45 pm.

Interviewer: what do you do in the afternoon?

Pedrito Pérez: I go back home, I change my clothes, eat lunch and rest. I watch TV from 1:15 pm to 3:30 pm. I study Mathematics and English at 4:00 pm, have a snack break and continue studying until 5:30 pm. Next, I play with my friends.

Interviewer: what do you do in the evening?

Pedrito Pérez: I do English homework for teacher Cesar Copete Valencia because he is very strict.

Interviewer: what do you do at night?

Pedrito Pérez: I listen to music and go to sleep at 9:00 p.m.

Interviewer: Thank you very much, Pedrito.

Pedrito Pérez: Thank you, mister interviewer.

According to the interview... De acuerdo con la entrevista...

21. Pedrito goes to school:

- a) 6:45 a.m.
- b) 6:20 a.m.
- c) 7:00 a.m.
- d) 6:15 a.m.

22. Pedrito studies:

- a) Until 2:00 p.m.
- b) Until 1:00 p.m.
- c) Until 12:45 p.m.
- d) Until 3:00 p.m.

23. Pedrito eats lunch:

- a) In the morning
- b) In the afternoon
- c) In the evening
- d) At night

According to the interview, choose the right option for every question. De acuerdo a la entrevista, escoja la opción correcta para cada pregunta.

24. What time is the interview?

- a) Before 7:00 am
- b) After 7:00 am
- c) Between 5 am and 6 am
- d) Between 5:30 and 6:30 am

25. Who makes breakfast at Pedrito's house?

- a) Him
- b) His mother
- c) His father
- d) His grandmother



26. When is the interview?

- a) On Monday
- b) On Thursday
- c) On Tuesday
- d) On Friday

Read the following conversation and choose the best option for the answer of the questions. Lea la siguiente conversación y elija las respuestas de las preguntas.

#### MY GRANDMOTHER'S PHONE CALL

**Luigi:** Hello.

**Grandmother:** Hello. Who is it?

**Luigi:** It's me, Luigi. Good morning, grandma. How are you today?

**Grandmother:** I'm very good, dear grandson. Are you busy? What are you doing?

**Luigi:** I am doing homework, grandma.

**Grandmother:** oh, ok, so you are very busy. What about your mother? Where is she?

**Luigi:** she's in the kitchen.

**Grandmother:** ok, and what is she doing?

**Luigi:** she's making supper, granny.

**Grandmother:** so she is also busy. What about Juan Diego?

**Luigi:** He's playing video games.

**Grandmother:** ok, Luigi. Say hello to everybody from me please. Goodbye.

**Luigi:** goodbye, granny.

27. What is Luigi doing?

- a) Doing homework.
- b) Listening to music.
- c) Playing video games.
- d) Reading a book.

28. What is Luigi's mom doing?

- a) She's making breakfast.
- b) She's making lunch.
- c) She's making supper.
- d) She's making a sandwich.

29. What is Juan Diego doing?

- a) He is doing homework.
- b) He is playing the guitar.
- c) He is listening to music.
- d) He is playing video games.

Read the text:

#### SUSAN'S DAILY ROUTINE

Susan is thirteen years old and she attends a very big school near London. Her favorite subjects are Science and Physical Education.

She is very good at sports. She plays volleyball at her school. Susan has a busy life. She always gets ups at a half past seven. She has a shower, gets dressed and at eight o'clock she goes to school by car

with her mother. Her classes start at half past eight.

Her mother is a teacher at Susan's school.

On Mondays Susan has lunch at school with her friends. On Tuesdays and Thursdays she practices volleyball at the school's gym. Wednesday is Susan's favorite day of the week because she has dance classes and sometimes she has dinner with her father. Susan's parents are divorced. She lives with her mother and on the weekends she always goes to her father's house.

On Saturdays Susan goes for a walk with her dog Nikita. After having lunch with her father, Susan goes to the cinema with some friends. At 4:40 pm Susan goes home and listens to music in her bedroom. She loves music. At 9:45 she goes to bed. She never goes to bed late.

30. It is true that:

- a) Susan gets up at 8:15 am.
- b) Susan gets up at 7:30 am
- c) Susan gets up at 7:45 am
- d) Susan gets up at 8:30 am

31. It is false that:

- a) On weekends she goes to her father's house.
- b) On weekends she goes to her mother's house.
- c) On weekends she goes for a walk with her dog Nikita.
- d) On weekends she goes to the cinema with some friends.

32. It is true that:

- a) Her classes start at 7:30.
- b) Her classes start at 8:30.
- c) Her classes start at 8:45.
- d) Her classes start at 8:00.

33. It is false that:

- a) She goes to the cinema on Fridays.
- b) She goes to the cinema on weekends.
- c) She goes to school during the week.
- d) She goes to school by car.

34. It is true that:

- a) She doesn't love music.
- b) She likes music.
- c) She plays basketball at her school's gym.
- d) She goes to piano classes.

Read the following text.

### **SOPHIE'S DAILY ROUTINE**

Sophie is eleven years old and she lives in Brighton, England. She usually gets up at a quarter to eight, she has a shower, gets dressed and then she brushes her teeth. After that, she goes downstairs and has breakfast. For breakfast she usually has milk, toast and orange juice. Then she brushes her teeth again because she likes them white and healthy!

Then she grabs her school bag and goes to the bus stop to catch the school bus. Classes start at half past eight and finish at half past four. She usually has lunch at the school canteen with her schoolmates at about 12 o'clock her best friend is Amy and Sophie always sits next to her at lunch.

After school she returns home and does her homework. She is a very hard-working pupil and she never misses a school task! After homework, she usually listens to music and watches television a bit.

At half past seven it is time for dinner. Then she usually reads a book or chats with her parents for a while.

Finally, she goes to bed at about ten o'clock, but before that she brushes her teeth. Sophie is a happy little girl!

Now choose the right option when answering the following questions.

35. What time does Sophie usually get up?  
a) Sophie usually gets up at 8:30 a.m.  
b) Sophie usually gets up at 9:30 a.m.  
c) Sophie usually gets up at 7:45 a.m.  
d) Sophie usually gets up at 11:30 a.m.
36. What does Sophie usually do immediately after she gets up?  
a) Sophie takes a shower immediately after getting up.  
b) Sophie brushes her teeth immediately after getting up.  
c) Sophie finishes school immediately after getting up.  
d) Sophie goes to bed immediately getting up.
37. What does Sophie do before starting classes?  
a) Sophie eats breakfast before starting classes.  
b) Sophie goes to bed before starting classes.  
c) Sophie finishes school before starting classes.  
d) Sophie has lunch before starting classes.

### SECTION E (PARAGRAPH ORGANIZATION)

38. Read the following sentences from the reading:

She goes to bed at about ten o'clock (1)

She gets dressed (2)

She catches the bus to school (3)

She has lunch at the school canteen (4)

She listens to music (5)

She gets up (6)

She does her homework (7)

She has a shower (8)

She has dinner (9)

According to the reading a logical order for Sophie's routine is:

- a) 1-3-5-7-9-2- 4-6-8  
b) 6-8-2-3-4-7-5-9-1  
c) 2-4-6-8-1-3-5-7-9  
d) 1-2-3-7-8-9-4-5-6

### SECTION F ( LANGUAGE USE)

39. Do you play tennis in winter?  
a) No, I doesn't  
b) No, I don't  
c) No, I'm not
40. Are you using a computer now?  
a) Yes, I'm  
b) Yes, I'm using  
c) Yes I am
41. Does Daniela like riding a bike?  
a) No. she isn't  
b) No, she hasn't  
c) No, she doesn't

42. Do you prefer being inside or outside?
- Yes, I do
  - I prefer being outside
  - I prefer be outside
43. Do you ever go skateboarding?
- No, hardly ever
  - No, hardly never
  - No, hardly always
44. Does Angelina make films?
- Yes, she is
  - Yes, she does
  - Yes, she has
45. Are Anderson and David playing a computer game?
- No, they are taking their English Exam
  - No, they´re take their English Exam
  - No, they take their English Exam
46. Where do you like going shopping?
- I am prefer to go to the shopping mall.
  - I prefer going to the shopping mall.
  - I do prefer to go the shopping mall.
47. Do your parents like going to the cinema?
- Yes, they do
  - Yes, it likes
  - Yes, they does
48. How often does Mariana go to school?
- She goes usually to school.
  - She does go usually to school.
  - She usually goes to school.

### **SECTION G (GRAMMAR)**

49. The negative version for the sentence "Sophie brushes her teeth three times a week" is:
- Sophie not brushes her teeth three times a week.
  - Sophie do not brush her teeth three times a week.
  - Sophie does not brushes her teeth three times a week.
  - Sophie does not brush her teeth three times a week.
50. The interrogative version for the sentence "She goes to school by bus" is:
- Do she goes to school by bus?
  - Does she goes to school by bus?
  - Does she go to school by bus?
  - Is she goes to school by bus?